

INSTRUCTION/INSTALLATION SHEET

CATEGORY 5 AUDIO KEYPAD VOLUME CONTROL WITH IR

IS-0313 REV. A

1. Introduction

This Audio Keypad Volume Control with IR, PN F7394-xx (**see Figure 1**), is an integral part of the Category 5 Multi-Room Audio System. It is a component which, when combined with other essential components and your source equipment (receiver, CD player, etc.), creates a versatile whole-house audio system that will fill your rooms with high-quality sound for years to come. The Category 5 Audio technology is an innovative method of providing high quality audio to remote locations with a single 8-conductor cable such as Category 5. This audio technology provides many advantages over other conventional methods of audio distribution such as simple, single Category 5 wiring scheme, infrared control of system components, and system power status.

2. Description

There are two (2) types of Category 5 volume controls offered by On-Q Legrand. The first type is the Amplified Volume Control (P/N F7399-IV, F7399-LA, or F7399-WH). It has a rotary knob for volume control and offers IR control. The second type is the Cat 5 Audio Keypad Volume Control with IR (P/N F7394-IV, F7394-LA or F7394-WH). It has push buttons for volume control, audio source selection, and muting. One volume control should be used for each room you choose to wire. The volume controls are terminated with Category 5 using a 110 style punchdown block located on the rear of the volume control.

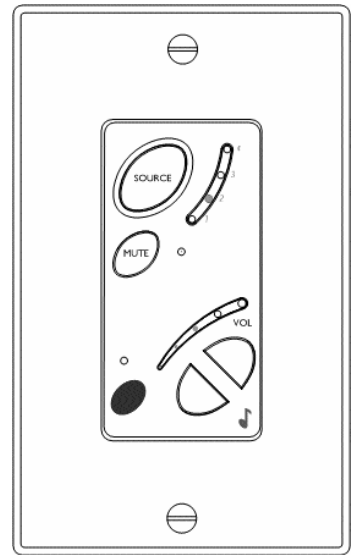

Figure 1

3. Installation

Installation of the Category 5 Audio Keypad Volume Control is best accomplished at multiple times during new construction, at “Rough-in” before the drywall is installed, and at “Trim-out” after the drywall is installed and painted.

NOTE: Before connecting the volume controls: Make sure the power supply is not connected to the Category 5 Audio Distribution Module. Make sure the Status input on the Single Source Input is not connected to power. Install volume controls last so you can make any volume trim adjustments on the volume control before installing it into the wall. For instructions on pre-wiring and installing other components of the Category 5 Audio System, please see the Instruction Sheets included with those components.

NOTE: All wiring should be terminated to the T568A wiring standard as shown in this document. Failure to follow the correct wiring standard could result in damaged equipment.

A. “Rough-in” steps:

- 1) A single Category 5 cable should be run from the enclosure location to a single gang outlet box or mud ring at each Volume Control location.

B. “Trim-out” steps:

INSTRUCTION/INSTALLATION SHEET CATEGORY 5 AUDIO KEYPAD VOLUME CONTROL WITH IR

IS-0313 REV. A

- 1) Terminate all volume controls by punching down the prewired Category 5 cable using a standard punch down tool with a 110 style blade. Maintain less than 1/2" of untwisting of pairs and make sure that the 110 blade cuts any excess conductor completely.

NOTE: By default, the keypad volume control is preset to operate in a Category 5 Audio System where all other volume controls in the system are keypads as well. The Audio System must be in ALL KEYPAD mode for WHOLE HOUSE commands to be available. In MIXED systems, the keypad remote controls in the system will respond to ROOM commands only.

- 2) If your system will contain a mix of both knob style and keypad style volume controls, you must reconfigure the keypad volume control by moving the jumper from "All Keypad" position to the "Mix" position.
 - a) Locate the volume control mode jumper located on the circuit board underneath the front plate of the volume control near the Mute button.
 - b) Move the jumper from the "All Keypad" position to the "Mix" position, as shown in **Figure 2**.

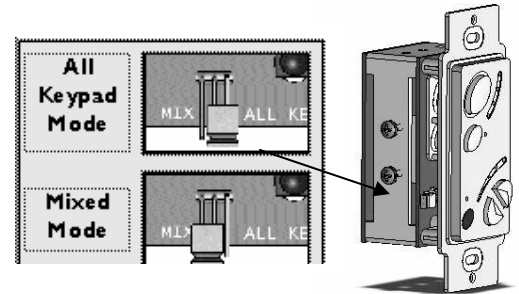
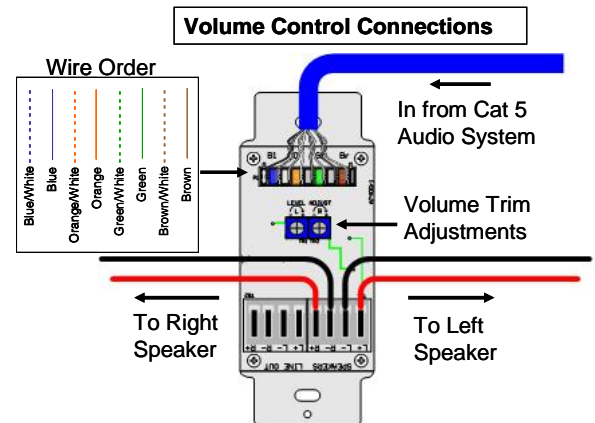

Figure 2

- 3) Speaker / Subwoofer / Line Out connections (see **Figure 3**):

NOTE: Polarity and channels are clearly marked (L+, L-, R+, R-) for proper identification during installation.

- a) Use the terminal connectors labeled "Speakers" to connect standard audio speakers (8 Ohm only) to the volume control.
- b) Use the terminal connectors labeled "Line Out" to connect either a powered subwoofer or an external amplifier to the volume control. These connection terminals do not provide any amplification but the volume control on the keypad controls the output level of this connection.



NOTE: Avoid Wiring Box Installation Interference by dressing Category 5 Cable into the punch down connector from the center of the Keypad Volume Control.

Figure 3

- 4) Volume Trim Adjustment (see **Figure 3**):
 - a) Two rotary trim potentiometers are located on the back of the volume control. These are to be used to set the maximum/minimum allowable volume level and to adjust left/right balance.

INSTRUCTION/INSTALLATION SHEET CATEGORY 5 AUDIO KEYPAD VOLUME CONTROL WITH IR

IS-0313 REV. A

- b) With the system on and music playing, use a small Phillips head screwdriver to adjust both the left and right potentiometer to the left most position (counter clockwise). The recommended adjustment method is to turn the volume all the way up and adjust the potentiometer up (clockwise) just before there is audio distortion.
- 5) Mounting: check all connections and test the system's operation before installing the volume controls into the wall. Use the included screws to install the volume control and wallplate into a standard single gang box.
- 6) Power Up Self Test: when power is initially applied to the keypad volume control, the following start up test will occur in the following order. - The blue keypad backlights will blink, then increment and stay on. - Each Source LED will blink green, incrementing down. - The Mute LED will blink red. - The Status/IR LED will blink green then red. - Each volume LED will light, first dim, then bright, and stay on, incrementing up until all are brightly lit. - All LEDs, including the blue backlights, will go out, and the keypad volume control will be in the OFF state.

C. Operation:

NOTE: The illuminated keypad of the volume control provides buttons for source selections, mute, and volume control. Pressing any key on the keypad will turn the volume control on. Pressing and holding the Mute button will turn the volume control off . (see Figure 4)

- 1) SOURCE BUTTON: When the keypad volume control is used in a system equipped with the Multi-Source Input and Multi-Source Module, the source button will toggle to the next source and the corresponding source LED will light. In systems without Multi-Source capability, the Source 1 LED will remain on and the keypad volume control will not respond when this key is pressed.
- 2) MUTE BUTTON: This button enables Mute mode. in Mute mode, the green source LED, blue backlights and the green volume LEDs will go out, the red LED next to the Mute button will be lit, and the amplifier will be off. Line Out will also be muted. Pressing the Mute button again will take the keypad volume control out of Mute mode and return it to its previous state. This key is also used to turn off the keypad volume control as described above.

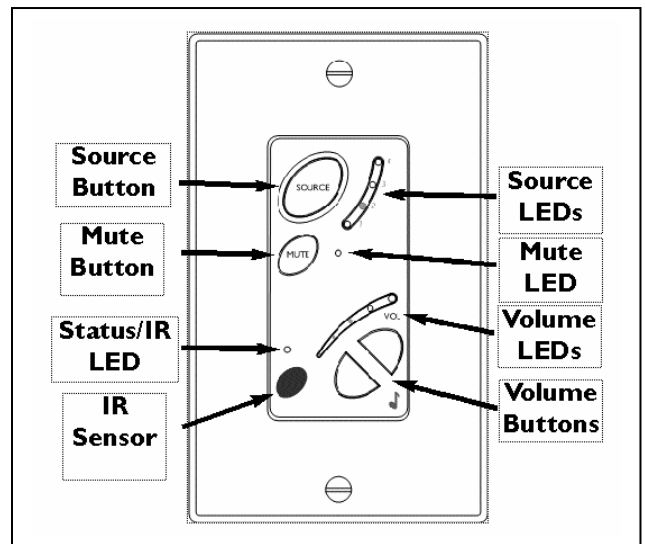

Figure 4

- 3) VOLUME BUTTONS: The volume up button and the volume down button control both speakers simultaneously. When all volume LEDs are brightly lit, maximum volume is obtained. When all the volume LEDs are not lit, no volume will be present.



301 Fulling Mill Road, Suite G
Middletown, PA 17057
Phone (800) 321-2343 / Fax (717) 702-2546
www.onqlegrand.com

INSTRUCTION/INSTALLATION SHEET

CATEGORY 5 AUDIO KEYPAD VOLUME CONTROL WITH IR

IS-0313 REV. A

- 4) IR RECEPTION/TRANSMISSION: The keypad volume control is capable of receiving a remote IR signal between 10 KHz and 110 KHz. The remote signal is passed through the whole audio system. The keypad volume control will only respond to custom audio command keys using the remote control specified for the Category 5 Audio System. The keypad volume control will pass throughout the system, but otherwise ignore, all other commands from third party remote controls that may be used to control other equipment, such as receivers, set top boxes, and video components.

When the custom audio commands from the Category 5 Audio System Remote Control, PN 7427, are issued in ROOM mode, only the keypad volume control that receives the command will respond. The other keypad volume controls in the system will not respond to ROOM commands. When the custom audio commands from the Category 5 Audio System Remote Control are issued in WHOLE HOUSE mode, all of the keypad volume controls in the system will respond. The WHOLE HOUSE function will time out 30 seconds after the last key press, or it can be deactivated by pushing the ROOM command. Pressing WHOLE HOUSE again before the 30 second time out will refresh the timer.

NOTE: Prior to using the WHOLE HOUSE commands, it is necessary to 'sync' all the volume controls by issuing a WHOLE HOUSE OFF command from a keypad volume control that is on. All the volume controls will then be in sync when a WHOLE HOUSE ON command is issued.

- 5) STATUS/IR LED -
- **Green:** source activity - **Red:** ROOM IR activity - **Orange:** WHOLE HOUSE activity
- 6) KEYPAD BRIGHTNESS LEVEL: The level of brightness is adjusted by pressing the keypad mute and keypad volume control buttons simultaneously. Pressing the Mute and Volume Up buttons at the same time increases backlight brightness while pressing the Mute and Volume Down buttons at the same time decreases backlight brightness.

4. Important Safety Precautions:

READ ALL INSTRUCTIONS CAREFULLY BEFORE INSTALLING THE CATEGORY 5 AUDIO SYSTEM.

- **Do not** attempt to service, move or change any component of this system unless you are qualified to do so.
- This system should be installed by a qualified installer and must conform to all local building and electrical codes.
- **Do not** apply power to the Category 5 Audio System until all components have been installed and all wiring has been properly terminated.
- **Do not** attempt to terminate, change or un-install any wiring without first turning off power at the Category 5 Audio System which is located in the enclosure. Unplug the power transformer that is powering the Category 5 Audio System from the power outlet before proceeding with wiring terminations or changes.
- Install each component of this system away from heat sources such as HVAC ducts/registers, stoves or any other heat source.
- **Do not** expose any component that was designed for indoor use to moisture. Doing so can create electrical hazards or render the component unusable. Exposure to moisture will also void the warranty on the system.
- Only use a damp cloth to clean the cover plates of the system components. Do not use vacuum cleaners, liquid or aerosol cleaners.